

## 17" 5-Wire Resistive Touchscreen Monitor



### FEATURES

- 17-Inch Screen Size / SXGA 1280 x 1024 Resolution
- Interface: DVI / VGA / Audio / USB Type-A / RS232
- 5-Wire Resistive Touch Technology
- Integrated Stereo Speakers
- 350 nits High Brightness
- Design for 24/7 Operation
- TAA Compliant
- 3-Year Warranty

### P17BH-AB-459G

SPECIFICATIONS	
Size	17 In
Resolution	SXGA 1280 x 1024
Display Area (mm)	337.9 (H) x 270.3 (V)
Aspect Ratio	5 : 4
Response Time	5ms
Viewing Angle	170° / 160°
Brightness	350cd/m <sup>2</sup>
Contrast Ratio	1000 : 1
Color	16.7M
Backlight	LED
Interface	DVI x1, VGA x1, USB-A x1, RS232 x1, Audio x1
Speaker	1W x 2
Touch Technology	Resistive
Touch Type	5-Wire
Touch Interface	USB Type-A / RS232
Support OS	Windows / Linux
IP Rating	IP65 (Option)
Cabinet Material	Plastic
Cabinet Color	Black
Power Consumption	TBD
Electrical Rating	AC 100V ~ 240V, 50/60Hz
Operating Temp.	32° F ~ 104° F (0° C ~ 40° C)
Storage Temp.	-4° F ~ 140° F (-20° C ~ 60° C)
Humidity	10% ~ 90%
Dimensions (In/mm)	15.4 x 15.0 x 7.0 / 392.3 x 381.5 x 180.2
Net Weight	14.3 lbs (6.5 kg)
Certification	CE / FCC
VESA™	100 x 100

*\*\*Specifications may change without any notice*

### DIMENSIONS

UNIT:MM

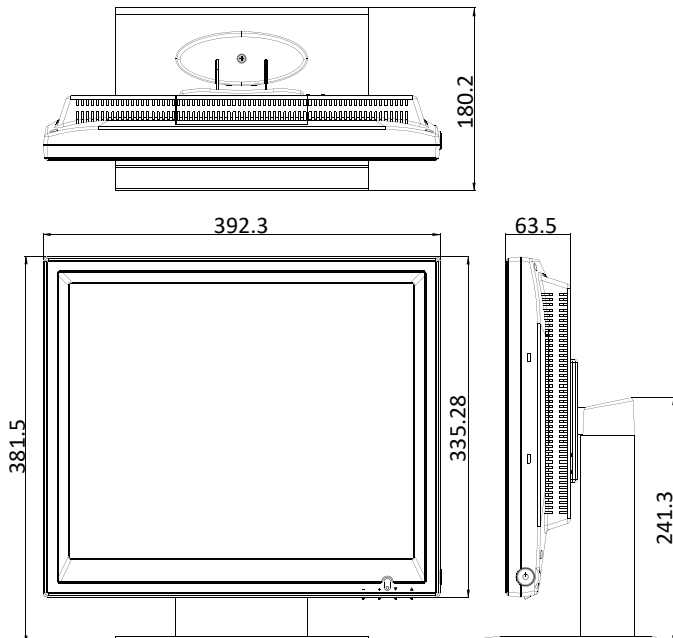

30398 Esperanza,  
Rancho Santa Margarita, CA 92688

888-651-9688 / 949-586-3338

sales@gvision-usa.com  
<https://www.gvision-usa.com>

